

SELLOS PARA AREAS PELIGROSAS SERIE EYS

FABRICACION BAJO NORMAS INTERNACIONALES



Secciones 6.1 y 6.2



Clase I, Div. 1 y 2, grupo A, B, C, D.

Clase II, Div. 1 y 2, grupo E, F, G.

Clase III, Div 1 y 2.

* Ver nota abajo

APLICACIONES:

- Impiden el paso de gases, vapores y flamas de una parte de la instalación eléctrica a otra de presión atmosférica y temperatura ambiente normales.

- Rosca NPT para usarse con tubo conduit RIGIDO.

- Posiciones: vertical u horizontal.

MATERIAL

- Aluminio libre de cobre inyectado a presión (Diecast).

ACABADOS

- Pintura electrostática termoendurecida.

INSTRUCCIONES

- Deberán colocarse a una distancia no mayor de 457 mm (18") de cualquier aparato que provoque chispas, arcos ó altas temperaturas.

- El espesor del cemento sellador no deberá de ser menor del diámetro de la tubería y en ningún caso menor a 16 mm (5/8").

- Especificaciones sujetas a cambios sin previo aviso.

**SE FABRICAN TAMBIEN
CON REVESTIMIENTO EXTERIOR DE PVC
E INTERIOR DE URETANO PURPURA**

Ficha Técnica 007-RW-265



**Puede trabajar indistintamente
en posición
horizontal ó vertical.**



**Opción versátil. NIPLE intercambiable
para convertir el sello a rosca macho.**

*



LISTED: EYS-0452, EYS-0453 and EYS-0550 for use in **Class I** Div. 1 & 2, group C,D, **Class II** Div. 1 & 2, group E,F,G, **Class III** Div. 1 & 2.



CERTIFIED: EYS-0452, EYS-0453, EYS-0550, EYS-2633, EYS-2634 and EYS-2635 for use in **Class I** Div. 1 & 2, group A,B,C,D, **Class II** Div. 1 & 2, group E,F,G, **Class III** Div. 1 & 2.



CERTIFIED: EYS-2633, EYS-2634 and EYS-2635 for use in **Class I** Div. 1 & 2, group C,D, **Class II** Div. 1 & 2, group E,F,G, **Class III** Div. 1 & 2.

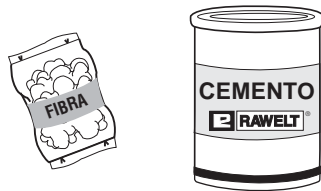
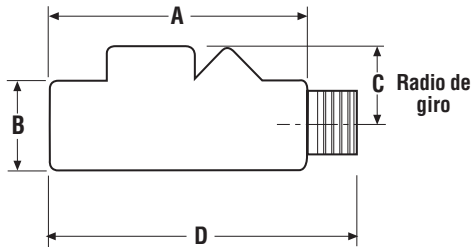
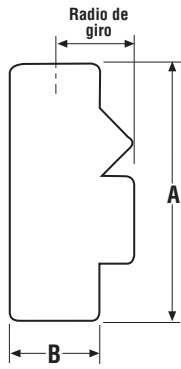

CEMENTO SELLADOR

EYS / DIMENSIONES:

Medida Nominal		A		B		Radio de giro		D	
mm	Inch	mm	Inch	mm	Inch	mm	Inch	mm	Inch
12.7	1/2"	97	3.82	34	1.34	32	1.26	130	5.12
19	3/4"	97	3.82	34	1.34	32	1.26	130	5.12
25.4	1"	108	4.25	44	1.73	37	1.46	147	5.79
31.75	1 1/4"	125	4.92	51	2.00	44	1.73	166	6.54
38.1	1 1/2"	140	5.51	58	2.28	54	2.13	185	7.28
50.8	2"	152	5.98	74	2.91	59	2.32	200	7.87

Ficha Técnica 007-RW-321

- El cemento sellador RAWELT se usa para impedir el paso de gases, vapores o flamas de una instalación eléctrica a otra de presión atmosférica y temperatura ambiente normales. Al aplicarlo se expande ligeramente formando un sello hermético. Es resistente a solventes ácidos, agua y aceites.
- La fibra se utiliza para crear una obstrucción que impide escurrimientos cuando se vierte el cemento en el sello.
- Véase instrucciones

TABLA DE EQUIVALENCIAS

Figura	Medida	RAWELT Catálogo	OZ GEDNEY Catálogo	APPLETON Catálogo	CROUSE HINDS Catálogo	C.H.DOMEX Catálogo	KILLARK Catálogo
	1/2"	EYS - 0452	EYA - 50	EYF - 50 AL	EYS - 11	-----	ENY - 1
		EYS - 0452-N	EYAM - 50	EYM - 50 AL	EYS - 116	-----	ENY - 1 - T
	3/4"	EYS - 0453	EYA - 75	EYF - 75 AL	EYS - 21	-----	ENY - 2
		EYS - 0453-N	EYAM - 75	EYM - 75 AL	EYS - 216	-----	ENY - 2 - T
	1"	EYS - 0550	EYA - 100	EYF - 100 AL	EYS - 31	-----	ENY - 3
		EYS - 0550-N	EYAM - 100	EYM - 100 AL	EYS - 316	-----	ENY - 3 - T
1 1/4"	EYS - 2633	EYA - 125	EYF - 125 AL	EYS - 41	EYS - 4	ENY - 4	
	EYS - 2633-N	EYAM - 125	EYM - 125 AL	EYS - 416	EYS - 46	ENY - 4 - T	
1 1/2"	EYS - 2634	EYA - 150	EYF - 150 AL	EYS - 51	EYS - 5	ENY - 5	
	EYS - 2634-N	EYAM - 150	EYM - 150 AL	EYS - 516	EYS - 56	ENY - 5 - T	
2"	EYS - 2635	EYA - 200	EYF - 200 AL	EYS - 61	EYS - 6	ENY - 6	
	EYS - 2635-N	EYAM - 200	EYM - 200 AL	EYS - 616	EYS - 66	ENY - 6 - T	

Fabricante:
RAWELT, S.A. de C.V.

Distribuidor para México:
BASCULAS REVUELTA, S.A. de C.V.
Torreón, Coah., México.

E-mail: rawelt_trc@revuelta.com.mx
www.rawelt.com.mx

Tel.: (871) 747-4747

Fax: (871) 747-4748

LADA SIN COSTO: 01-800-7117-200 (Para México)

INVECTADOS



Una División del Grupo **REVUELTA**

Sucursales en: Guadalajara, Monterrey, México, D.F., Hermosillo, Puebla, Irapuato, Mérida.
Sucursal en Guatemala, C.A. Distribuidores en: Todo Centro y Sur América.

RW 12 / 0905.3

DISTRIBUIDOR AUTORIZADO. Fono: (56)2-966 8227. Mail: info@sinteg.cl

**6.1 - SELLOS PARA AREAS PELIGROSAS. SERIE EYS.
LIBRE DE COBRE.**

**6.1 - SEALING FITTINGS FOR HAZARDOUS LOCATIONS. EYS SERIES.
COPPER FREE ALUMINUM.**

Hoja: 1 / 3
Page:

FICHA TECNICA / TECHNICAL DATA

007 - RW - 209

Para dimensiones:
Ver Ficha Tecnica 007 - RW-321
Clase I, Div. 1 y 2, grupo A, B, C, D.
Clase II, Div. 1 y 2, grupo E, F, G.
Clase III, Div. 1 y 2.

*** Ver nota abajo**

APLICACIONES:

- Impiden el paso de gases, vapores y flamas de una parte de la instalación eléctrica a otra de presión atmosférica y temperatura ambiente normales.
- Rosca NPT para usarse con tubo conduit RIGIDO.
- Posiciones: vertical u horizontal.

MATERIAL

- Aluminio libre de cobre inyectado a presión (diecast).

ACABADOS

- Pintura electrostática epoxica/poliester polimerizada.

OPCIONAL

- Niple removible de acero galvanizado.

INSTRUCCIONES

- Deberán colocarse a una distancia no mayor de 457 mm (18") de cualquier aparato que provoque chispas, arcos ó altas temperaturas.
- El espesor del cemento sellador no deberá de ser menor del diámetro de la tubería y en ningún caso menor a 16 mm (5/8").
- Fabricación en base a: UL 886
CAN/CSA - C22.2 No. 30
UL 1203



LISTED
16TM



For dimensions:

See Technical Data 007 - RW - 321

Class I, Div. 1 & 2, group A, B, C, D.
Class II, Div. 1 & 2, group E, F, G.
Class III, Div. 1 & 2.

*** See note below**

APPLICATIONS:

- Restrict the passage of gases, vapors, liquids, dust and flames from one portion of the electrical installation to another at atmospheric pressure and normal ambient temperatures.
- NPT threaded for use with RIGID conduit.
- Vertical and Horizontal positions.

MATERIAL

- Diecast copper free aluminum

FINISH

- Electrostatic powder epoxy/poliester coating

OPTIONAL

- Galvanized removable Nipple

INSTRUCTIONS

- Are to be installed within 18" of a device that produce sparks, arcs or high temperature.
- The thickness of the sealing compound shall not be less than the trade size of conduit and in no case less than 5/8".
- Manufactured in compliance with: UL 886
CAN/CSA - C22.2 No. 30
UL 1203

CERTIFICACIONES / COMPLIANCES: CSA LR - 105795 - 6
UL E1 98859

USAR No. DE CODIGO PARA HACER PEDIDOS / TO ORDER USE CODE NUMBER

Figura Figure	Catalogo Catalog	Codigo Code	Medida nominal Hub size		Tapón llenado Filling plug mm. / inch		Numero y tamaño de conductor Number and size of conductor THW	Peso x 100 pzas. Weight x 100 pcs.		Unit Ctn. Pzas. Pcs.	Ship Ctn. Pzas. Pcs.	Std. Pkg. Pzas. Pcs.
			mm.	inch	horiz.	vert.		Kg	Lb			
	EYS-0452	04.10.2326	12.7	1/2	19.0 3/4	6.35 1/4	7 # 18 AWG	24	53			54
	EYS-0453	04.10.2331	19.0	3/4	19.0 3/4	6.35 1/4	10 # 16 AWG	21	46			54
	EYS-0550	04.10.2336	25.4	1	25.4 1	6.35 1/4	10 # 14 AWG	28	61			60
	EYS-2633	04.10.2891	31.75	1 1/4	31.75 1 1/4	12.7 1/2	13 # 10 AWG	33	73			46
	EYS-2634	04.10.2892	38.1	1 1/2	38.1 1 1/2	19.0 3/4	10 # 8 AWG	53	117			30
	EYS-2635	04.10.2893	50.8	2	50.8 2	19.0 3/4	10 # 6 AWG	86	190			20

*** LISTED:** EYS-0452, EYS-0453 and EYS-0550 for use in **Class I** Div. 1 & 2, group C,D. **Class II** Div. 1 & 2, group E,F,G. **Class III** Div. 1 & 2.



CERTIFIED: EYS-0452, EYS-0453, EYS-0550, EYS-2633, EYS-2634 and EYS-2635 for use in **Class I** Div. 1 & 2, group A,B,C,D. **Class II** Div. 1 & 2, group E,F,G. **Class III** Div. 1 & 2.



CERTIFIED: EYS-2633, EYS-2634 and EYS-2635 for use in **Class I** Div. 1 & 2, group C,D. **Class II** Div. 1 & 2, group E,F,G. **Class III** Div. 1 & 2.

Especificaciones sujetas a cambio sin previo aviso.

Specifications are subject to change without notice.

RAWELT, S.A. de C.V.



22 - V - 2009

Una División del Grupo **REVELTA**

6.1 - SELLOS PARA AREAS PELIGROSAS. SERIE EYS.
LIBRE DE COBRE.

6.1 - SEALING FITTINGS FOR HAZARDOUS LOCATIONS. EYS SERIES.
COPPER FREE ALUMINUM.

Hoja: 2 / 3
Page:

FICHA TECNICA / TECHNICAL DATA
007 - RW - 209

USAR No. DE CODIGO PARA HACER PEDIDOS / TO ORDER USE CODE NUMBER

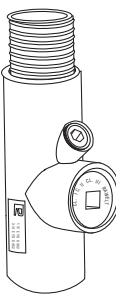
Figura Figure	Catalogo Catalog	Codigo Code	Medida nominal Hub size		Tapón llenado Filling plug mm. / inch		Numero y tamaño de conductor Number and size of conductor THW	Peso x 100 pzas. Weight x 100 pcs.		Unit Ctn. Pzas. Pcs.	Ship Ctn. Pzas. Pcs.	Std. Pkg. Pzas. Pcs.
			mm	inch	horiz.	vert.		kg	Lb			
	EYS-0452-N	04.10.2561.N	12.7	1/2	19.0 3/4	6.35 1/4	7 # 18 AWG	27	60			40
	EYS-0453-N	04.10.2562.N	19.0	3/4	19.0 3/4	6.35 1/4	10 # 16 AWG	25	55			40
	EYS-0550-N	04.10.2563.N	25.4	1	25.4 1	6.35 1/4	10 # 14 AWG	38	84			50
	EYS-2633-N	04.10.2894.N	31.75	1 1/4	31.75 1 1/4	12.7 1/2	13 # 10 AWG	48	106			40
	EYS-2634-N	04.10.2895.N	38.1	1 1/2	38.1 1 1/2	19.0 3/4	10 # 8 AWG	66	146			25
	EYS-2635-N	04.10.2896.N	50.8	2	50.8 2	19.0 3/4	10 # 6 AWG	106	233			13

USAR No. DE CODIGO PARA HACER PEDIDOS / TO ORDER USE CODE NUMBER

Figura Figure	Catalogo Catalog	Codigo Code	Medida Hub size		Tapón / Close-up plug	Peso x 100 pzas. Weight x 100 pcs.		Pqt. Unit Pzas. Pcs.	Unit Ctn. Pzas. Pcs.	Ship Ctn. Pzas. Pcs.
			mm	inch		kg	Lb			
	TA-2939	04.24.2939	6.35	1/4	Vaciado vertical	0.900	1.98	25		
	TA-2943	04.24.2943	12.7	1/2	Vertical filling	0.835	1.80	25		800
	TA-2938	04.24.2938	19.0	3/4	Vaciado vert. y horiz. / Vert. & hor. filling	1.700	3.75	25		800
	TA-2937	04.24.2937	25.4	1	Vaciado horizontal	2.720	6.00	20		600
	TA-2636	04.24.2940	31.75	1 1/4		3.900	8.60	10		330
	TA-2637	04.24.2941	38.1	1 1/2	Horizontal filling	5.960	13.10	10		330
	TA-2638	04.24.2942	50.8	2		8.540	18.80	10		200



COMPUESTO SELLADOR Y FIBRA.
SEALING COMPOUND AND FIBER.



- El compuesto sellador RAWELT es usado para impedir el paso de gases, vapores o flamas de una instalación eléctrica a otra de presión atmosférica y temperatura ambiente normales.
- La fibra es utilizada para crear una obstrucción para impedir escurrimientos a la tubería cuando se vierte el compuesto en el sello.
- El compuesto sellador RAWELT se expande ligeramente para formar un sello completamente hermético.
- Es resistente a solventes, ácidos, agua y aceites.
- Tiempo de curado: 12 horas a 20°C.

- The sealing compound RAWELT is used to restrict the passage of gases, vapors or flames from one portion of the electrical installation to another at atmospheric pressure and normal ambient temperatures.
- The fiber is used to form a dam to restrict drains to the conduit when pour the sealing compound in the sealing fitting.
- The sealing compound RAWELT expands slightly to form a seal completely hermetic.
- Is resistant to solvents, acids, water and oil.
- Curing time: 12 hours at 68°F.

USAR No. DE CODIGO PARA HACER PEDIDOS / TO ORDER USE CODE NUMBER

Figura Figure	Catalogo Catalog	Codigo Code	Peso neto del producto Net weight of product		Volumen al curar Volume when set		Unit Ctn. Pzas. Pcs.	Ship Ctn. Pzas. Pcs.	Std. Pkg. Pzas. Pcs.
			kg	lb	cm ³	cu. in			
	CE-2571	04.22.2571	1 kg*	2.20 lb	833	50.8			10
	FB-06	04.22.2578	60 g	2.11 oz					40
	FB-10	04.22.2579	100 g	3.52 oz					36
	FB-25	04.22.2580	250 g	8.81 oz					14
	FB-50	04.22.2581	500 g	1.10 lb					5

• La presentación de 1 kg se surte con 60 g de fibra. / The container of 2 lb. includes 2 Oz. of fiber.
Especificaciones sujetas a cambio sin previo aviso. Specifications are subject to change without notice.

RAWELT, S.A. de C.V.



Una División del Grupo REVUELTA

22 - V - 2009

DISTRIBUIDOR AUTORIZADO. Fono: (56)2-966 8227. Mail: info@sinteg.cl

6.1 - SELLOS PARA AREAS PELIGROSAS. SERIE EYS.
LIBRE DE COBRE.
6.1 - SEALING FITTINGS FOR HAZARDOUS LOCATIONS. EYS SERIES.
COPPER FREE ALUMINUM.

Hoja: 3 / 3
Page:

FICHA TECNICA / TECHNICAL DATA

007-RW-209

NIPLES / NIPPLES

USAR No. DE CODIGO PARA HACER PEDIDOS / TO ORDER USE CODE NUMBER

Figura Figure	Catalogo Catalog	Codigo Code	Medida nominal Hub size		Peso x 100 pzas. Weight x 100 pcs.		Pqt. Unit. Pzas. Pcs.	Unit Ctn. Pzas. Pcs.	Ship Ctn. Pzas. Pcs.	Std. Pkg. Pzas. Pcs.
			mm	inch.	kg	Lb				
				NI-13	04.21.2576	12.7				
	NI-19	04.21.2577	19.0	3/4	5	11.0	25		650	
	NI-25	04.21.2573	25.4	1	10	22.0	25		225	
	NI-32	04.21.3233	31.7	1 1/4	10	22.0	10		200	
	NI-38	04.21.3234	38.1	1 1/2	12	26.5	10		150	
	NI-50	04.21.3235	50.8	2	20	44.0	10		60	

RAWELT, S.A. de C.V.

 **RAWELT**® INYECTADOS

Una División del Grupo  **REVUELTA**

04 - IX - 2007

DISTRIBUIDOR AUTORIZADO. Fono: (56)2-966 8227. Mail: info@sinteg.cl

6.1 - SELLOS PARA AREAS PELIGROSAS. SERIE EYS.

PREPARACION DEL CEMENTO SELLADOR

6.1 - SEALING FITTINGS FOR HAZARDOUS LOCATIONS. EYS SERIES.

PREPARATION OF THE SEALING COMPOUND.

Hoja: 1 / 2
Page:

FICHA TECNICA / TECHNICAL DATA

007-RW-321

- El compuesto sellador **RAWELT** es usado para impedir el paso de gases, vapores o flamas de una instalación eléctrica a otra de presión atmosférica y temperatura ambiente normales.
- La fibra es utilizada para crear una obstrucción para impedir escurrimientos a la tubería cuando se vierte el compuesto en el sello.
- El compuesto sellador **RAWELT** se expande ligeramente para formar un sello completamente hermético.
- The sealing compound **RAWELT** is used to restrict the passage of gases, vapors or flames from one portion of the electrical installation to another at atmospheric pressure and normal ambient temperatures.
- The fiber is used to form a dam to restrict drains to the conduit when pour the sealing compound in the sealing fitting.
- The sealing compound **RAWELT** expands slightly to form a seal completely hermetic.

Taponeado y vaciado Damming and Pouring

Posición Horizontal Horizontal Position

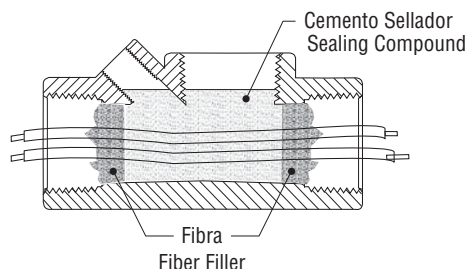

Class I, Div. 1 y 2, grupo A, B, C, D.

Class II, Div. 1 y 2, grupo E, F, G.

Class III, Div. 1 y 2.

* Ver nota abajo



LISTED
16TM



Class I, Div. 1 & 2, group A, B, C, D.

Class II, Div. 1 & 2, group E, F, G.

Class III, Div. 1 & 2.

* See note below

Taponeado y vaciado Damming and Pouring

Posición Vertical Vertical Position

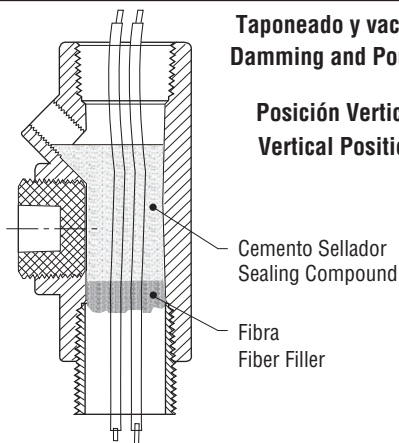

INSTRUCCIONES: Agite la lata para mezclar perfectamente el contenido antes de cada uso.

- Separe cada conductor, empaque la fibra apretándola alrededor de cada conductor, y entre las paredes del sello. Los conductores no deben tocarse entre sí, ni tampoco a las paredes del sello.
- Añada 1 parte de agua fría por 3 partes de compuesto por volumen; mezcle perfectamente y deposítelo en el sello usando una varilla para distribuir la mezcla dentro del sello no dejando ninguna burbuja en el compuesto sellador hasta que el compuesto este a la altura de el último hilo de la boca pequeña en la posición vertical y hasta 2 hilos cubiertos en la posición horizontal; ciérralo con el tapón roscado inmediatamente después de vaciado.

PRECAUCIONES: Cierre la lata de compuesto perfectamente después de cada uso; el manejo incorrecto del compuesto, su mala aplicación, las condiciones ambientales e impurezas, pueden causar un sellado defectuoso.

- No use la mezcla después de 15 minutos de haber vaciado el agua, ni la prepare a temperaturas menores de 1.7°C. (35°F). Si el compuesto empieza a secarse, no intente rebajarlo con agua o revolviendolo, esto arruina el compuesto.
- El tiempo de curado dependerá de la temperatura ambiente. Aproximadamente: 12 horas a 20°C. (68°F); 72 horas a 4.4°C (40°F).
- Para instalaciones de GRUPO A, el compuesto sellador deberá tener un tiempo de curado de 72 horas, antes de energizar el sistema.
- Resistente a solventes, ácidos, agua y aceites.

INSTRUCCIONES: Mix and shake perfectly contents before each use.

- Separate each conductor, pack the fiber around and between each conductor and wall of the fitting. The conductor must not touch one another nor touch the wall of the fitting.
- Add 1 part of cold water to 3 parts compound by volume, thoroughly stir and pour it thoroughly into sealing fitting carefully using a stick to distribute into it until the compound is level with the last thread of the opening for the vertical conduit and until 2 threads are covered of the horizontal conduit. Be sure do not leave any bubbles into the sealing compound. Close with the plugs the sealing fitting after pouring.

CAUTION: Close firmly the container lid after each use; the wrong handling, failure in applications, humid or moisture conditions and impurities may produce a faulty seal.

- Do not mix the compound with water in amounts, than can not be use within 15 minutes, nor temperatures below 35°F (1.7°C). If the compound starts to set do not attempt to thin it by adding water or by stirring, this procedure spoil the compound.
- The curing time depends with the temperature. For example: 68°F (20°C) - 12 hours., 40°F (4.4°C) - 72 hours.
- For group A installations, sealing compound must be allowed 72 hours to cure.
- Resistant to solvents, acids, water and oil.

DIAMETRO ENTRADAS / NUMERO Y TAMAÑO DEL CONDUCTOR THW
Hub Size / Number and size of conductor TWH

1/2	7 # 18 AWG	1 1/4	13 # 10 AWG
3/4	10 # 16 AWG	1 1/2	10 # 8 AWG
1	10 # 14 AWG	2	10 # 6 AWG



LISTED:
EYS-0452, EYS-0453
and EYS-0550 for use in
Class I Div. 1 & 2, group C, D.
Class II Div. 1 & 2, group E, F, G.
Class III Div. 1 & 2.



STD CSA-C22.2 No.30

CERTIFIED: EYS-0452, EYS-0453,
EYS-0550, EYS-2633, EYS-2634 and
EYS-2635 for use in Class I Div. 1 & 2,
group A, B, C, D. Class II Div. 1 & 2,
group E, F, G. Class III Div. 1 & 2.



CERTIFIED: EYS-2633, EYS-2634
and EYS-2635 for use in
Class I Div. 1 & 2, group C, D.
Class II Div. 1 & 2, group E, F, G.
Class III Div. 1 & 2.

RAWELT, S.A. de C.V.

RAWELT INYECTADOS

22 - V - 2009

Una División del Grupo **REVELTA**

DISTRIBUIDOR AUTORIZADO. Fono: (56)2-966 8227. Mail: info@sinteg.cl

6.1 - SELLOS PARA AREAS PELIGROSAS. SERIE EYS.
LIBRE DE COBRE.

Hoja: 2 / 2
Page:

6.1 - SEALING FITTINGS FOR HAZARDOUS LOCATIONS. EYS SERIES.
COPPER FREE ALUMINUM.

FICHA TECNICA / TECHNICAL DATA

007-RW-321

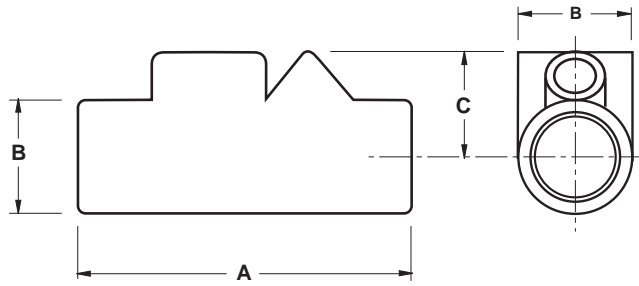

SELLO HEMBRA		FEMALE SEALING FITTING											
Catalogo Catalog	Código Code	Medida Nominal Hub size		A		B		Radio de giro Turning radius C		Cemento sellador requerido Sealing cement required		Fibra requerida por pieza Fiber required required by pc.	
		mm	Inch.	mm	Inch.	mm	Inch.	mm	Inch.	g	oz	g	oz
EYS-0452	04.10.2326	12.7	1/2	97	3.82	34	1.34	32	1.26	50	1.75	1.00	0.036
EYS-0453	04.10.2331	19.0	3/4	97	3.82	34	1.34	32	1.26	71	2.50	1.70	0.060
EYS-0550	04.10.2336	25.4	1	108	4.25	44	1.73	37	1.46	100	3.50	3.70	0.130
EYS-2633	04.10.2891	31.75	1 1/4	125	4.92	51	2.00	44	1.73	255	9.02	7.08	0.250
EYS-2634	04.10.2892	38.1	1 1/2	140	5.51	58	2.28	54	2.13	340	12.00	14.17	0.500
EYS-2635	04.10.2893	50.8	2	152	6.00	74	2.91	59	2.32	595	21.00	28.34	1.00

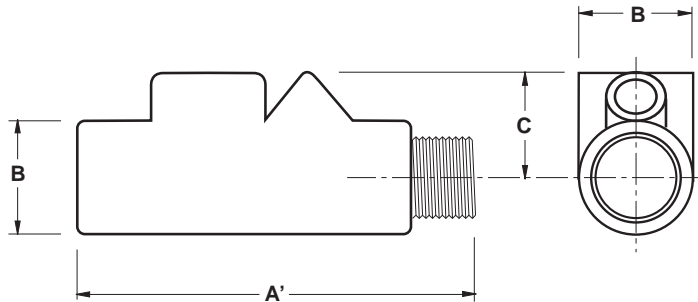

SELLO MACHO-HEMBRA		MALE-FEMALE SEALING FITTING											
Catalogo Catalog	Código Code	Medida Nominal Hub size		A'		B		Radio de giro Turning radius C		Cemento sellador requerido Sealing cement required		Fibra requerida por pieza Fiber required required by pc.	
		mm	Inch.	mm	Inch.	mm	Inch.	mm	Inch.	g	oz	g	oz
EYS-0452-N	04.10.2561.N	12.7	1/2	130	5.12	34	1.34	32	1.26	50	1.75	1.00	0.036
EYS-0453-N	04.10.2562.N	19.0	3/4	130	5.12	34	1.34	32	1.26	71	2.50	1.70	0.060
EYS-0550-N	04.10.2563.N	25.4	1	147	5.79	44	1.73	37	1.46	100	3.50	3.70	0.130
EYS-2633-N	04.10.2894.N	31.75	1 1/4	166	6.54	51	2.00	44	1.73	255	9.02	7.08	0.250
EYS-2634-N	04.10.2895.N	38.1	1 1/2	185	7.28	58	2.28	54	2.13	340	12.00	14.17	0.500
EYS-2635-N	04.10.2896.N	50.8	2	200	7.87	74	2.91	59	2.32	595	21.00	28.34	1.00

RAWELT, S.A. de C.V.



Una División del Grupo REVUELTA

22 - V - 2009

DISTRIBUIDOR AUTORIZADO. Fono: (56)2-966 8227. Mail: info@sinteg.cl

Cotización/Quotation Plazo de embarque* / Shipment exw* :

Pedido No./Purchase order :

Our ref.:

Fecha/Date: Vendedor/Salesman: No.

Facturar a/Invoice to: RFC:

Ordenado por/Ordered by: Tel. () Fax ()

Dirección/Address:





..... C.P./Zip. Lugar/City/Country:

Consignar a/Ship to:

..... Embarcar: Camión x Cobrar Pagado Paquete

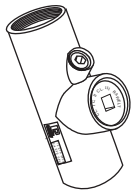
Cond. de Pago/Terms:

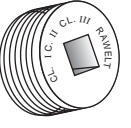
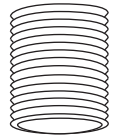
Cond. de Venta/Sale conditions: L.P.:

6.1 - SERIE EYS. SELLOS PARA AREAS PELIGROSAS/SEALING FITTINGS FOR HAZARDOUS LOCATIONS.								
Figura Figure	Código Code	Medida nominal Hub size		Pqt. Unit.	Unit. Ctn.	Ship Ctn.	Std. Pkg.	Cantidad Qty.
		mm	inch	Pzas. Pcs.	Pzas. Pcs.	Pzas. Pcs.	Pzas. Pcs.	
	04.10.2326	12.7	1/2				54	
	04.10.2331	19.0	3/4				54	
	04.10.2336	25.4	1				60	
	04.10.2891	31.7	1 1/4				46	
	04.10.2892	38.1	1 1/2				30	
	04.10.2893	50.8	2				20	
	04.10.2561.N	12.7	1/2				40	
	04.10.2562.N	19.0	3/4				40	
	04.10.2563.N	25.4	1				50	
	04.10.2894.N	31.7	1 1/4				40	
	04.10.2895.N	38.1	1 1/2				25	
	04.10.2896.N	50.8	2				13	
	04.24.2939	6.35	1/4	25				
	04.24.2943	12.7	1/2	25		800		
	04.24.2938	19.0	3/4	25		800		
	04.24.2937	25.4	1	20		600		
	04.24.2940	31.7	1 1/4	10		330		
	04.24.2941	38.1	1 1/2	10		330		
	04.24.2942	50.8	2	10		200		
	04.21.2576	12.7	1/2	25		900		
	04.21.2577	19.0	3/4	25		650		
	04.21.2573	25.4	1	25		225		
	04.21.3233	31.7	1 1/4	10		200		
	04.21.3234	38.1	1 1/2	10		150		
	04.21.3235	50.8	2	10		60		
	* 04.22.2571	Peso / weight					10	
		1 kg						
	04.22.2578	60 g					40	
	04.22.2579	100 g					36	
	04.22.2580	250 g					14	
	04.22.2581	500 g					5	

* La presentación de 1 kg se surte con 60 g de fibra.

• Antes de fincar el pedido en firme, favor de confirmar con fábrica el plazo de embarque definitivo.
• Before place your order, please confirm with RAWELT definitive date of shipment.

Producción Almacén Embarques Control Expediente

Cliente

Ing. de Ventas